

DIMENSIONS:

MECHLIFT 410

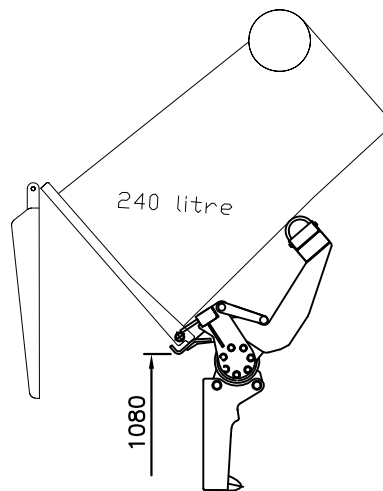
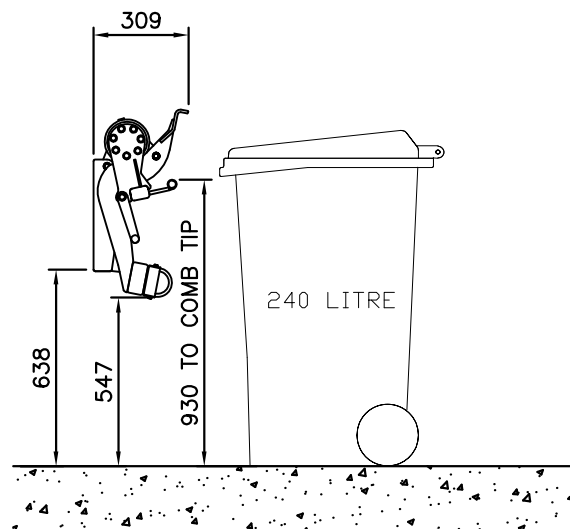
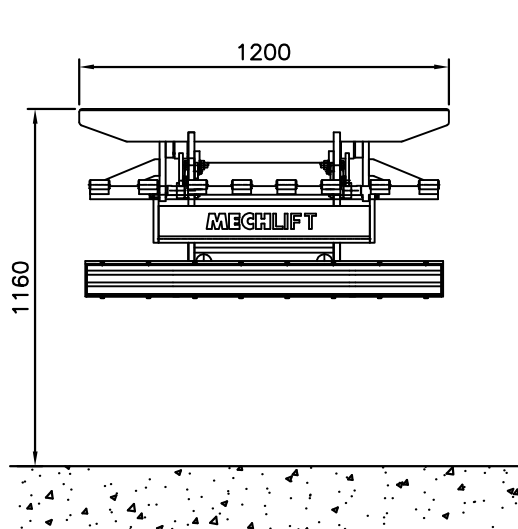

FOR INSTALLATION AND MORE COMPREHENSIVE DETAILS, PLEASE VISIT WWW.MECHLIFT.COM

SPECIFICATIONS:

LIFTER TYPE:	Low Level
BIN TYPE:	2 x 240 litre
CYCLE TIME:	7 – 8 seconds
TIPPING ANGLE:	45 degrees
LIFTING CAPACITY:	300 Kg
HYDRAULIC PRESSURE:	150 bar
HYDRAULIC FLOW:	18 litre/min
NOISE LEVEL:	< 72 dBA
SHIPPING DIMENSIONS:	1200 x 628 x 309mm
LIFTER MASS:	150 Kgs

FEATURES:

1. Rugged, low-cost lifter for 240 liter bins only.
2. Low Level Lifter, bags and hand managed refuse can easily be loaded
3. Proven actuator kinematics, uses the same principle as all Mechlift lifters, which have proven to be the best and most reliable lifters available over the past ten years.
4. Weight – this is kept to the minimum through a simple yet robust design, thus resulting in bigger pay loads

OTHER:

The ML 410 has been designed to handle the tough local conditions and stand up to abuse. Due to the limited number of moving parts, maintenance is kept to a minimum and a longer life expectancy can be achieved.
No exposed cylinder rods to be damaged or ingest dirt.